

# Most Economic Comfort



INTERNATIONAL QUALITY OPHTHALMIC EQUIPMENTS MADE AVAILABLE TO YOU IN INDIA AT DOMESTIC PRICES

Refraction Unit  
**PO-EU**



ISO 9001 : 2000 CERTIFIED



**Plantech**  
MEDICAL SYSTEMS  
PRIVATE LIMITED

# Refraction Unit PO-EU

A classic piece of workmanship in this ergonomically designed unit being popularly used in the medical and the optical trade. Most modern hospitals, clinics and optical showrooms opt for this product for patients's examination.

This combination of instruments and equipment's mounted on this equipment limits patients movements, and helps the operator with convenient speedier mode of examination. The quality of electronic components, raw materials, painting procedures and workmanship set aside this brand from the others.

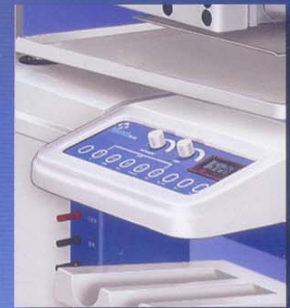

## CHAIR

Elevation Storks	: 200 mm.
Seat Height	: 560 mm. to 760 mm.
Inclination of Backrest	: 100 to 175 Degrees
Rotation (Optional)	: 0 to 180 Degrees
Power Source	: 220 V A/C 50 Hz.
Power Consumption	: 660 VA.
Net Weight	: 110 Kgs.
Load Lifting Capacity	: 175 Kgs.

## STAND UNIT

Power Supply	: 0, 1.5, 2.5, 3, 4, 6, 7.5, 9 & 12 V Selections for table mounted equipments
Loaded Weight	: 25 Kg. on right and left side.
Height From Floor	: 865 mm.
Tray Movement	: 0 to 90 Degrees
Table Top Size	: 405 mm. X 785 mm.
Trial Lens Set Tray Size	: 550 mm. X 345 mm. X 15 mm.
Base Plate	: 850 mm. X 950 mm.
Light pole Length	: 1093 mm. X 42 mm. Diameter
Prescription Table	: 405 mm. X 430 mm.
Table / Retinoscope	
Ophthalmoscope	: Voltage Range : 0, 1.5, 2.5, 3, 4, 6, 7.5, 9 & 12 V From 2 AMP Transformer
Fuse	: Slow Blow Type
Power Source	: 220 V A.C.
Net Weight	: 152 Kgs.
Optional	: Left Sided stand is also available : Arm for vision Tester

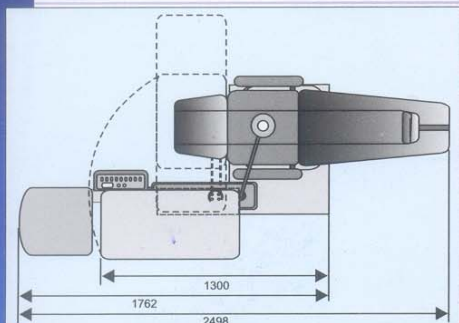
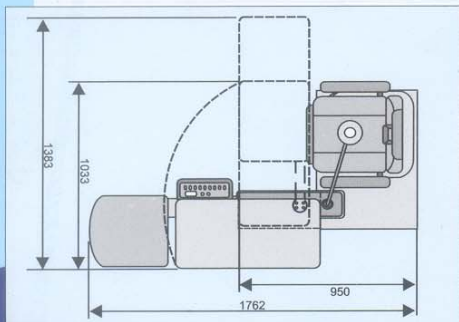

Subject to change in design and / or specification without advance notice.

MANUFACTURED BY  
**Plantech**  
MEDICAL SYSTEMS  
PRIVATE LIMITED

58, TIRUPATI IND. ESTATE,  
NR. JAY BHARAT RANGSHALA COMP.,  
B/H. AMBER CINEMA, SARASPUR,  
AHMEDABAD - 380 024 (INDIA)  
TEL : (079) 2274 8813, 2274 9913  
FAX : (079) 2276 0870  
E-mail : pms@icenet.net / info@plantechindia.com  
Web : www.plantechindia.com

Our Distributors :

